

THIS DRAWING IS UNPUBLISHED. RELEASED FOR PUBLICATION
 © COPYRIGHT BY TYCO ELECTRONICS CORPORATION. ALL RIGHTS RESERVED.

LOC	DIST	REVISIONS					
G	14	P	LTR	DESCRIPTION	DATE	DWN	APVD
		M		REV PER 0G3A-0029-05	18JAN05	JR	MS

AMP WIRE RANGE	Listed FILE E13288
22-16 AWG SOLID OR STRANDED	22-16 AWG SOLID OR STRANDED
LR7189 Certified	MILITARY P/N AND CLASS
22-16 AWG SOLID OR STRANDED	M7928/7-2 CLASS 2 P/N 34104 & 2-34104-6 ONLY

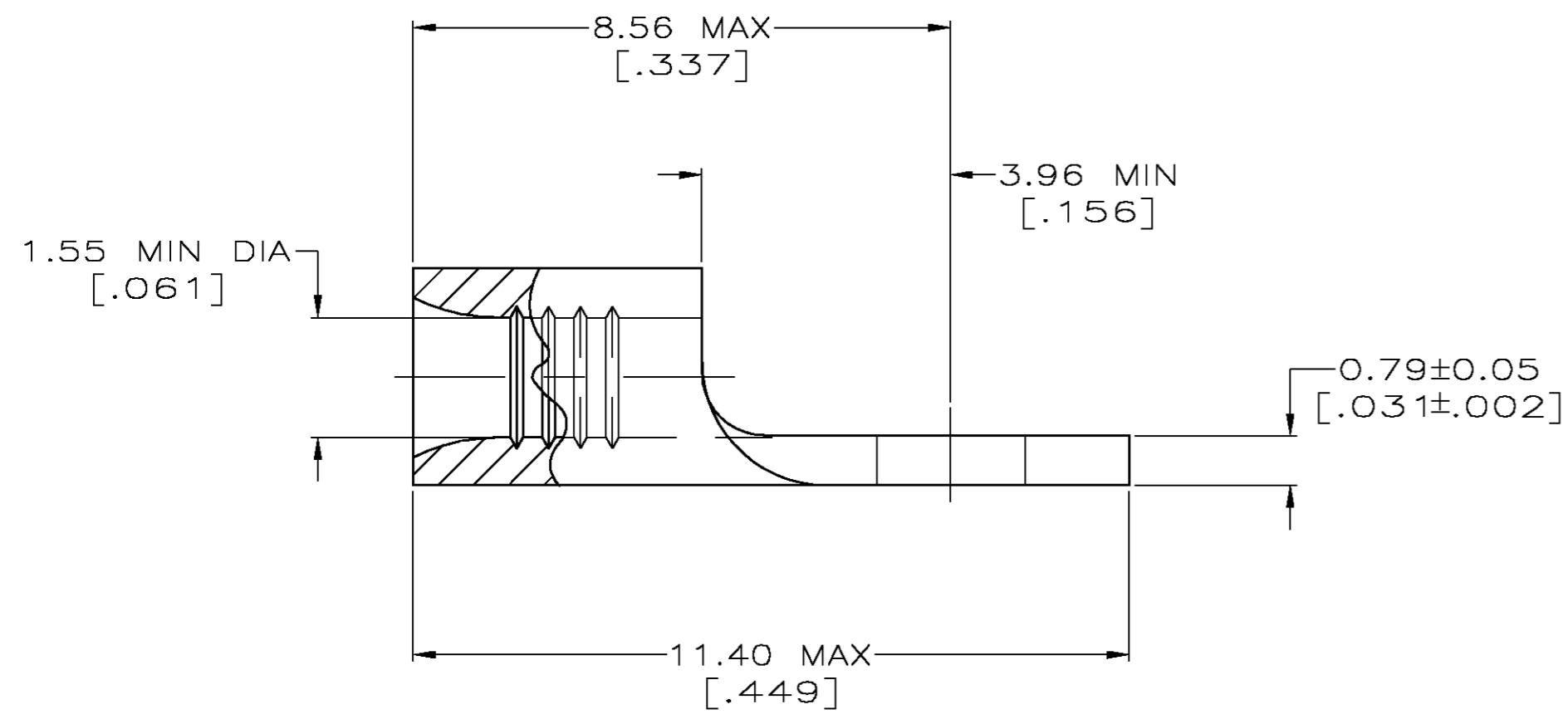
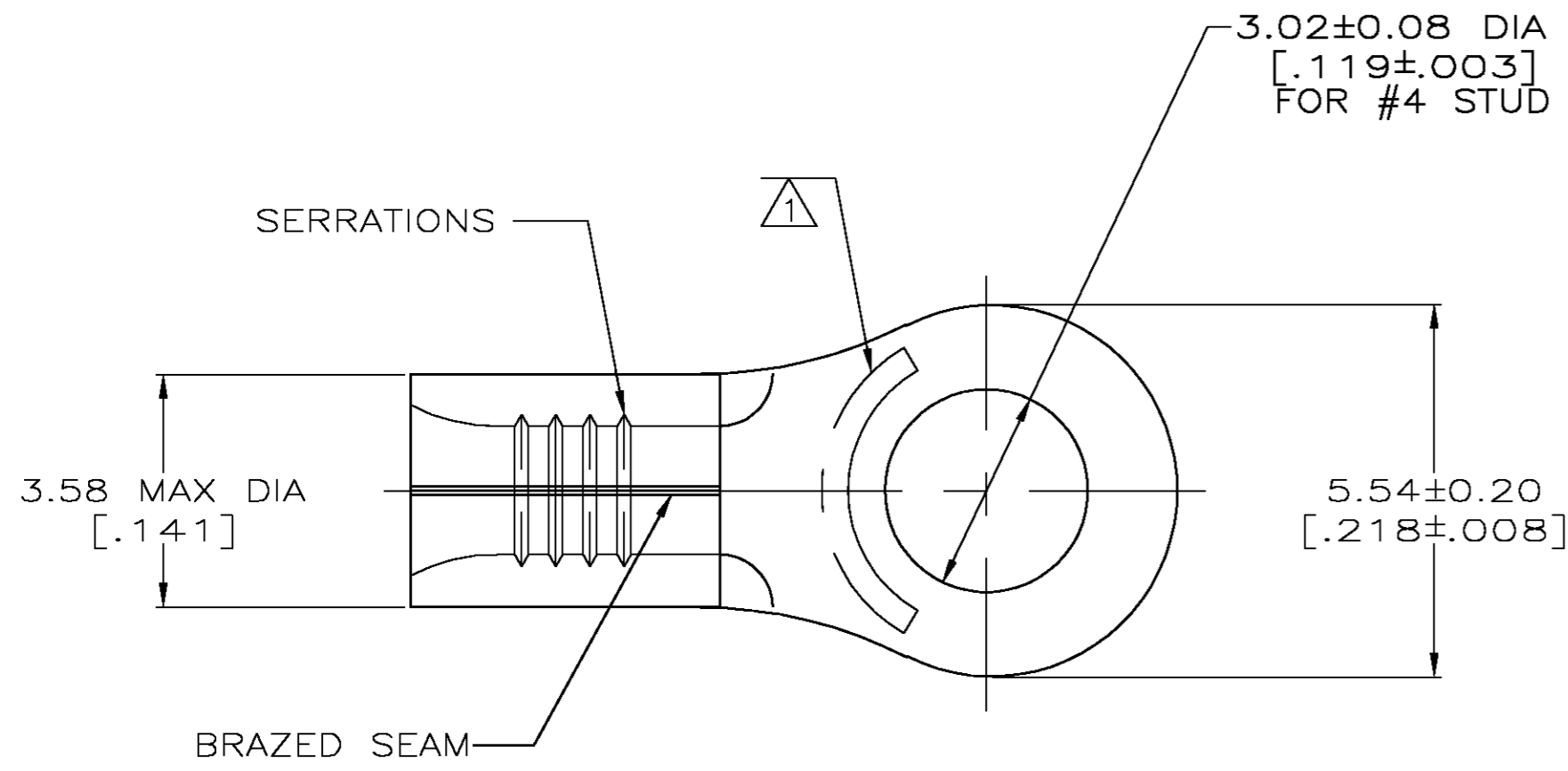

- ① STAMP AMP 22-18* APPROX AS SHOWN
22-16 TERMINALS ARE STAMPED 22-18 IN ACCORDANCE WITH MILITARY SPECIFICATION MIL-T-7928; COMMERCIAL WIRE RANGE IS 22-16
- ② TIN PLATE 0.00254 [.000100] MIN THK PER ASTM-B-545.
- ③ TIN LEAD PLATE 0.01016-0.02032 [.000400-.000800] THK PER MIL-P-81728
- ④ GOLD PLATE, .000100 MIN THK PER ASTM B-488 OVER NICKEL PLATE .000050 MIN THK PER SAE-AMS-QQ-N-290.
- ⑤ PRELIMINARY - NOT FOR PRODUCTION
- ⑥ PREPRODUCTION - FASR REQ
- ⑦ CLEANED, UNPLATED
- ⑧ .000300 MIN THK NICKEL PER QQ-N-290
- ⑨ COPPER PER ASTM B-152, ANNEALED

FINISH	QTY	PACKAGE TYPE	PART NO.
②	100	LOOSE PIECE, BOX	8-34104-1
②	5000	ON TAPE	2-34104-6
⑧	-	LOOSE PIECE	⑥ 34104-6
⑦	-	LOOSE PIECE	34104-5
④	-	LOOSE PIECE	34104-4
③	5000	ON TAPE	⑤ 34104-3
③	-	LOOSE PIECE	⑥ 34104-2
②	-	LOOSE PIECE	34104

AMP INCORPORATED CUSTOMER SERVICE SYSTEMS		MAX RECOMMENDED OPERATING TEMPERATURE: 170°C
FOR ADDITIONAL PRODUCT INFORMATION OR COPIES OF DRAWINGS AND TECHNICAL DOCUMENTS	PRODUCT INFORMATION CENTER 1-800-522-6752	VOLTAGE RATING: N/A
FOR APPLICATION TOOLING INFORMATION	TOOLING ASSISTANCE CENTER 1-800-722-1111	CIRCULAR MIL AREA: 0.26-1.65mm² [509-3260] SOLID OR STRANDED
FOR ORDER ENTRY	1-800-526-5142	THIS DRAWING IS A CONTROLLED DOCUMENT FOR AMP INCORPORATED. IT IS SUBJECT TO CHANGE AND THE CONTROLLING ENGINEERING ORGANIZATION SHOULD BE CONTACTED FOR THE LATEST REVISION.

THIS DRAWING IS A CONTROLLED DOCUMENT.		DWN TA BRINKMAN 3-10-93	Tyco Electronics Corporation Harrisburg, Pa 17105-3608	
DIMENSIONS: MM [INCHES]		CHK DA PATTERSON 3-10-93	NAME JL MECKLEY	
TOLERANCES UNLESS OTHERWISE SPECIFIED: 0 PLC ± - 1 PLC ± - 2 PLC ± - 3 PLC ± - 4 PLC ± - ANGLES ± -		APVD 3-10-93	PRODUCT SPEC APPLICATION SPEC	
MATERIAL - ⑨	FINISH SEE TABLE	WEIGHT -	SIZE A2	CAGE CODE 00779
CUSTOMER DRAWING		SCALE 10:1	DRAWING NO C=34104	RESTRICTED TO -
		SHEET 1	OF 1	REV M

34104

A